



American
COVERS
INCORPORATED

certified
WBENC
WOMEN'S BUSINESS ENTERPRISE



OUR STORY	4
OUR VISION	5
SAFETY	6
SAFETY AFFILIATES	7
FABRIC SHELTER 20' W	8
FABRIC SHELTER 30' W	11
FABRIC SHELTER 40' W	14
END PANELS	18
ACCESSORIES	19
CONTACT US	20

OUR MANIFESTO

American Covers is fully equipped to provide fast and easy turnkey solutions for our clients' lunch tent needs, including seating, flooring, lighting, fencing and plant safety certified installation crews.

OUR BEGINNINGS

American Covers Inc. was formed in 1995 with the purpose of fabricating and supplying fabric shelters for the petrochemical industries along the Gulf Coast. Our first sale was a 20' x 20' lunch tent used during a turn-around at a local refinery. Once both plant managers and the onsite industrial contractors saw our lunch tent and American Covers commitment to quality, additional orders soon followed. Before long our products expanded to include fabrication tents, warehouse storage tents, welding shelters and numerous other types of temporary shelters. Over the last twenty years American Covers has evolved into a recognized leader in providing temporary fabric shelters to refineries, chemical plants, industrial contractors and commercial businesses nationwide.

American Covers' success is directly attributed to its dedication in assembling a team of talented managers and motivated employees. Together, they work to consistently earn our customers' business by providing the best service possible each and every day. Daily safety huddles remind our team that they are the most important aspect of our company. Earnings are continuously reinvested in employee enrichment, continuing education, safety programs and training, as well as innovative product design and lean 6S manufacturing practices. The company is right sized in its ability to provide custom products and services on demand, and large enough to earn the trust of many Fortune 500 companies. Many of our current customers have been using our products since American Covers' beginning.



OUR VISION

SHARED COMMITMENT

We seek customers who share our commitment to safety, environmental responsibility and the design of value added products and services.

CONTINUED SUCCESS

We sustain profitable growth by developing existing markets and developing new opportunities that are consistent with our core competencies and purpose.

POSTIVE IMPACT

We attract and retain the best talent as a result of integrating a fun, positive work environment, leadership and people development with recognition and incentives.

OUR CORE VALUES

ETHICS

We are committed to high ethical standards of business conduct.

CULTIVATION

We are committed to a culture of excellence which defines our attitudes and behaviors-a requirement to make our purpose a reality

TEAMWORK

We recognize teamwork is the basis for our achievements. Leadership, integrity, flexibility and efficiency guide our actions to accomplish our purpose.

RECOGNITION

We acknowledge that our strength is based on the talent and commitment of our employees. Therefore, we dedicate resources toward their development, reward and recognition.

COMMITTED TO EXCELLENCE

American Covers Inc. recognizes safety as a core value and, as such, it is managed as a critical business activity. Every employee understands that safety is an essential element of career success.

TRAINING

All American Covers employees are continuously trained on the following safety components:

- Job Safety Analysis (JSA)
- Safety performance observation
- Near miss reporting
- Incident investigation
- Root Cause Analysis

OHSA

Our OSHA statistics reflects the success of this approach. We believe that all accidents are preventable with proper training, planning and follow up. Safety is priority one on all projects, regardless of size or duration. We promote a workplace environment designed to reduce the likelihood of accidents. By enforcing our comprehensive safety program, requiring regular safety training, and recognizing safe work practices, our employees have a clear expectation that American Covers expects excellence in work safety at all times.

CONTINUOUS IMPROVEMENT

Our OSHA statistics reflects the success of this approach. We believe that all accidents are preventable with proper training, planning and follow up. Safety is priority one on all projects, regardless of size or duration. We promote a workplace environment designed to reduce the likelihood of accidents. By enforcing our comprehensive safety program, requiring regular safety training, and recognizing safe work practices, our employees have a clear expectation that American Covers expects excellence in work safety at all times.

"Safety impacts every aspect of American Covers' success. Diligent safety practices allow us to be more competitive, and it benefits our customers with lower product and service cost. No job is so important, or requires completion so quickly, that we will not take the necessary time to perform it safely."

Rick Fogarty, Chief Financial Officer

SAFETY AFFILIATIONS



American Covers Inc. employees are routinely trained to comply with plant safety requirements and hold current OSHA, Plant Specific and TWIC certifications.

SAFETY CREDENTIALS

American Covers field installers hold the following safety credentials: Transportation Workers Identification Credential (T.W.I.C.), O.S.H.A. Basic Plus and numerous plant site specifics. Our field installers receive their continuous safety training and site specifics through the following organizations: Alliance Safety Council, Gulf Coast Safety Council (G.C.S.C.) Houston Area Safety Council (H.A.S.C.), Safety Council of Southwest Louisiana (S.W.L.A.), International Safety Training Council (I.S.T.C.)

SAFETY AFFILIATES

American Covers Inc. is a member of the following safety verification organizations: ISNetworld and Avetta. These industries recognized organizations, collect self-reported conformance information from vendors, verify its accuracy, and then reports the results in an easy to follow dashboard format.

DRUG SCREENING

American Covers employees are active members of DISA drug testing consortium and comply with random drug and alcohol screening requirements. Employees are tested for pre-employment, random, post-accident and reasonable suspicion.

BACKGROUND SCREENING

All American Covers field installers are required to consent to a background screening process. The background screenings are through DISA, First Advantage or I.S.T.C. The employee background screening services provide the most current and accurate data available and gives each client the ability to order and track employee background screens online.

FABRIC SHELTER LUNCH TENT / MATERIALS STORAGE 20' WIDE MODELS

SIZE

20'W 9'H at center; 6' sidewall

FRAME

Single Tube, High Strength Galvanized Steel Tubing

FABRIC

18 oz Poly Coated Vinyl Flame Resistant NFPA 701



SEATING

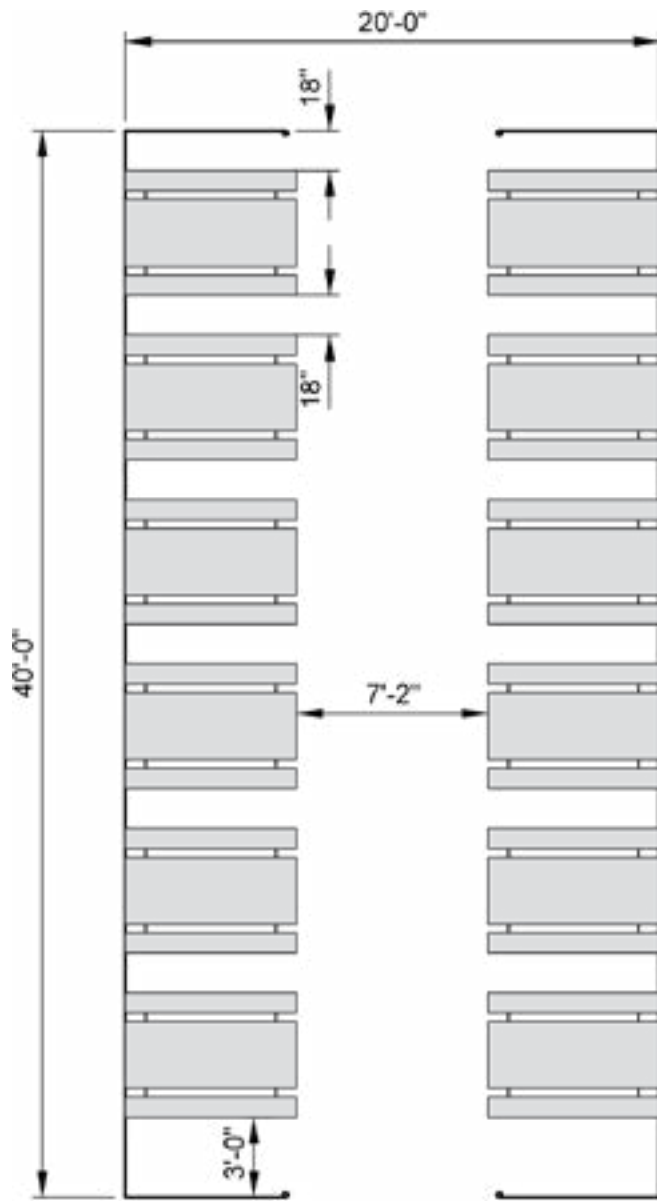

20' X 40' SHELTER
12 TABLES

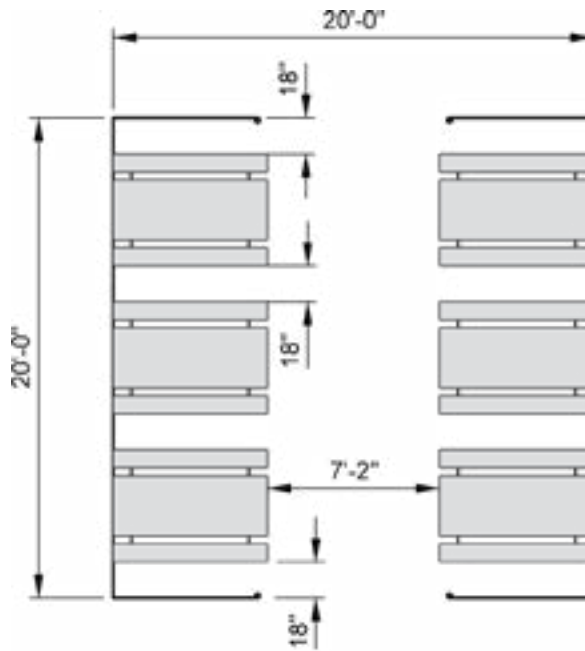
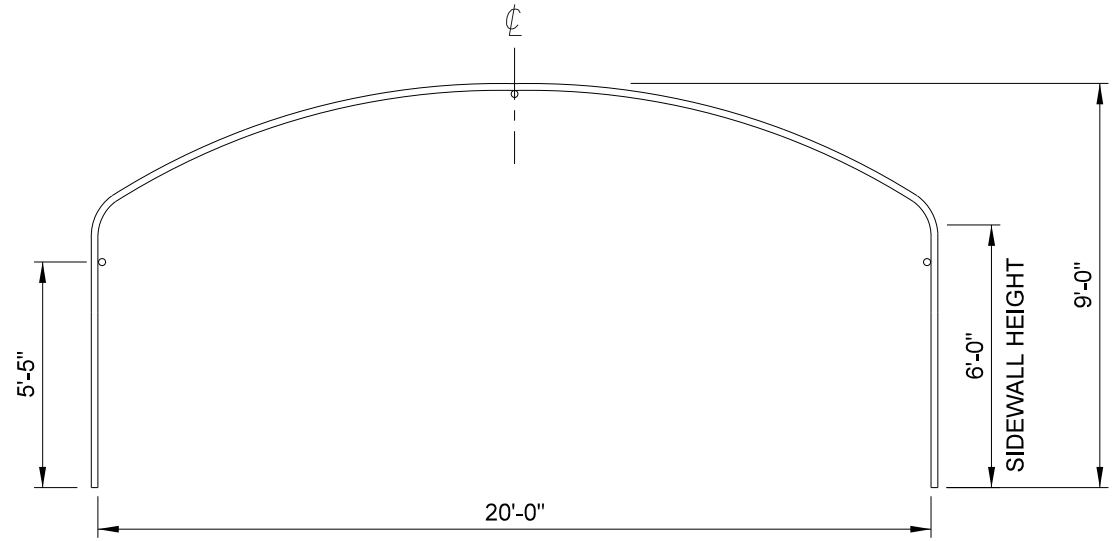

20' X 20' SHELTER
6 TABLES

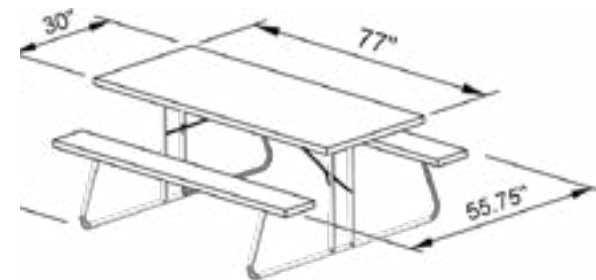
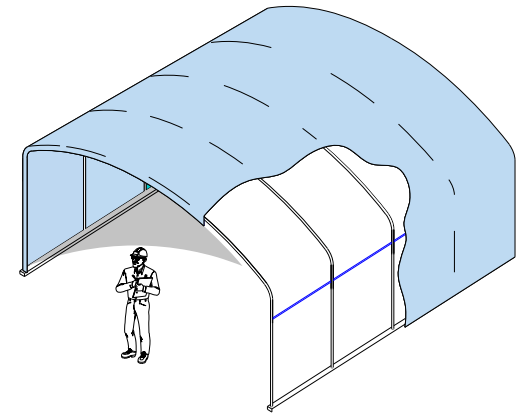

BENCH STYLE TABLE

FABRIC SHELTER DRIVE THROUGH/MATERIALS STORAGE 20' WIDE MODELS

SIZE

20'W 17'H at center; 13' sidewall

FRAME

Single Tube, High Strength Galvanized Steel Tubing

FABRIC

18 oz Poly Coated Vinyl Flame Resistant NFPA 701

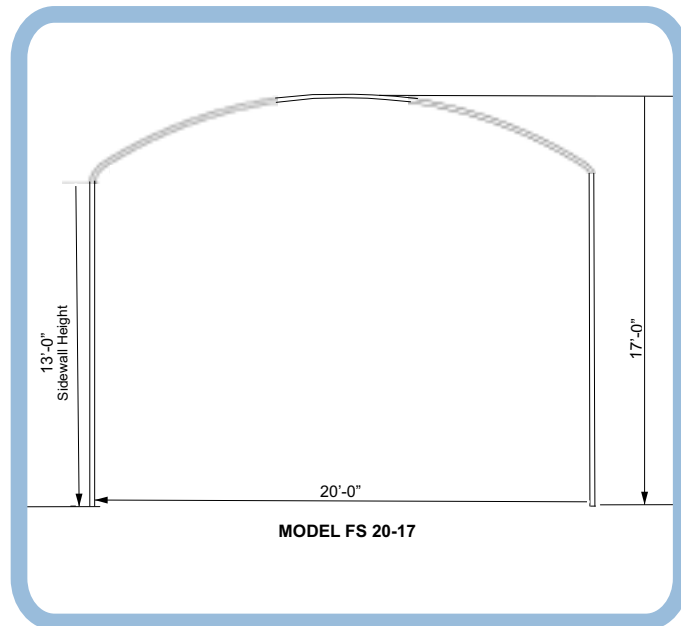

FABRIC SHELTER LUNCH TENT/ MATERIALS STORAGE 30' WIDE MODELS

SIZE

30'W 14'H or 16'H at center; 7'-6" Sidewall

FRAME

Single Tube, High Strength Galvanized Steel Tubing

FABRIC

18 oz Poly Coated Vinyl Flame Resistant NFPA 701



SEATING

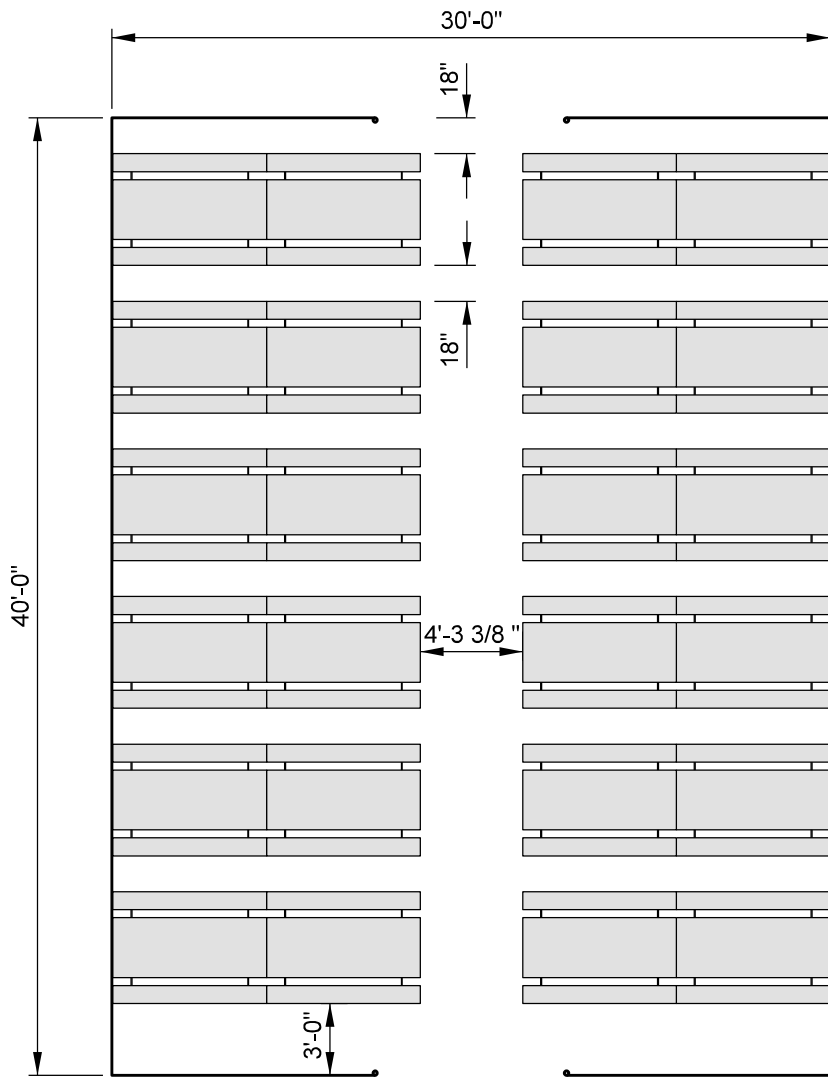

30' X 40' SHELTER
24 TABLES

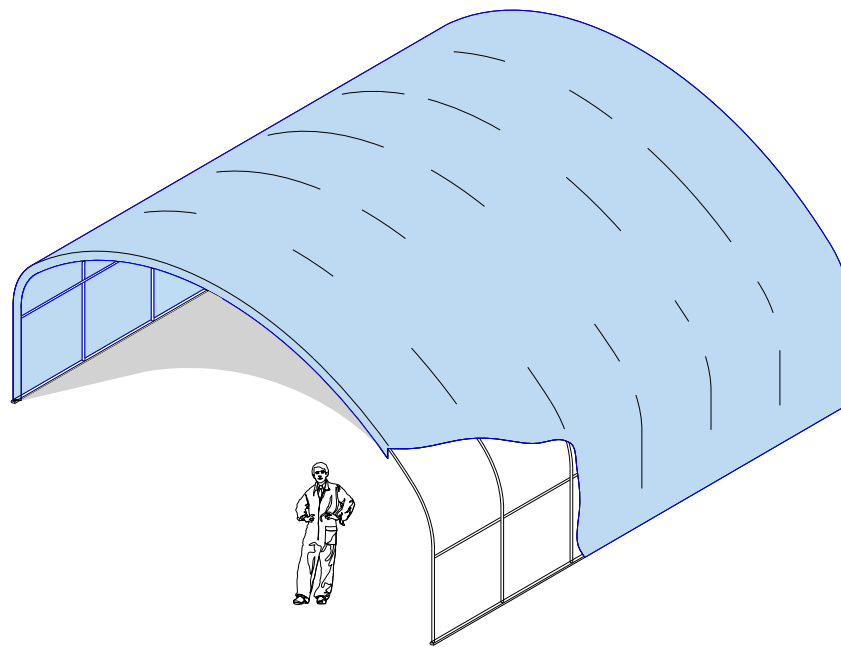
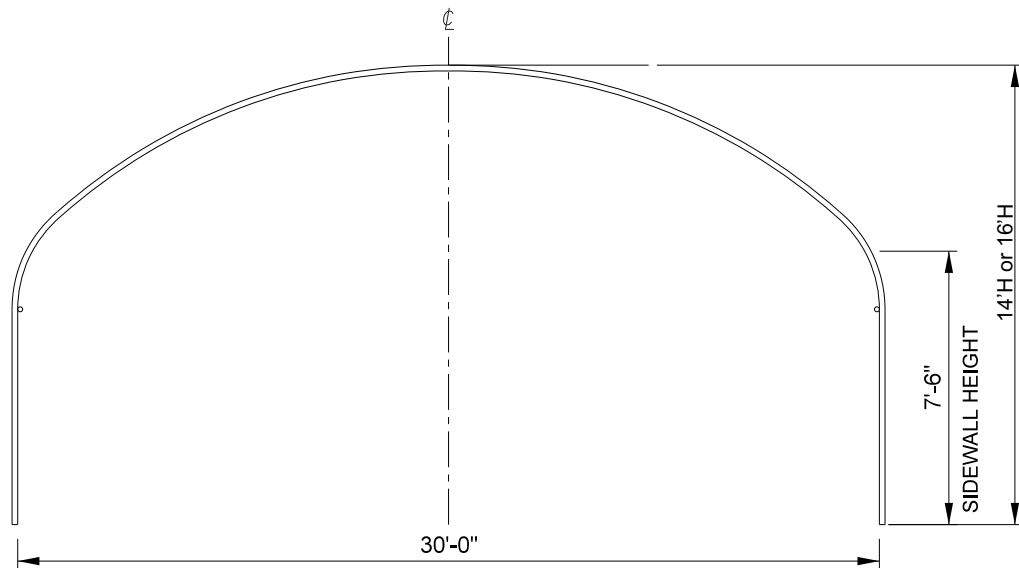

TRUSS FABRIC SHELTER MATERIALS STORAGE 30' WIDE MODELS

SIZE

30'W 20'H at center; 13'-0" Sidewall

FRAME

Single Tube, High Strength Galvanized Steel Tubing

FABRIC

18 oz Poly Coated Vinyl Flame Resistant NFPA 701

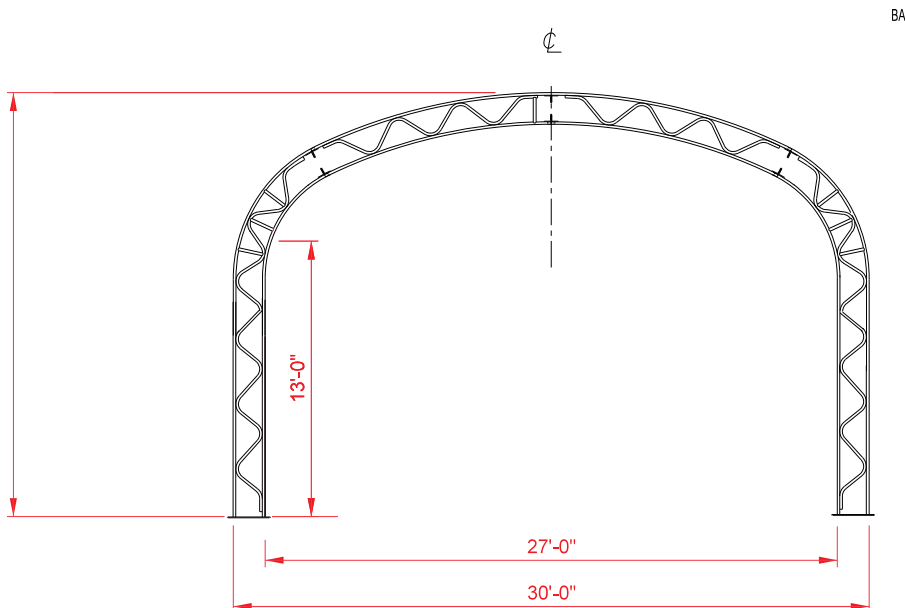

FABRIC SHELTER LUNCH TENT 40' WIDE MODELS

SIZE

40'W 14'H at center; 9'3" sidewall 16'H at center; 11' sidewall

FRAME

Truss Frame, High Strength Galvanized Steel Tubing

FABRIC

18 oz Poly Coated Vinyl Flame Resistant NFPA 701



SEATING

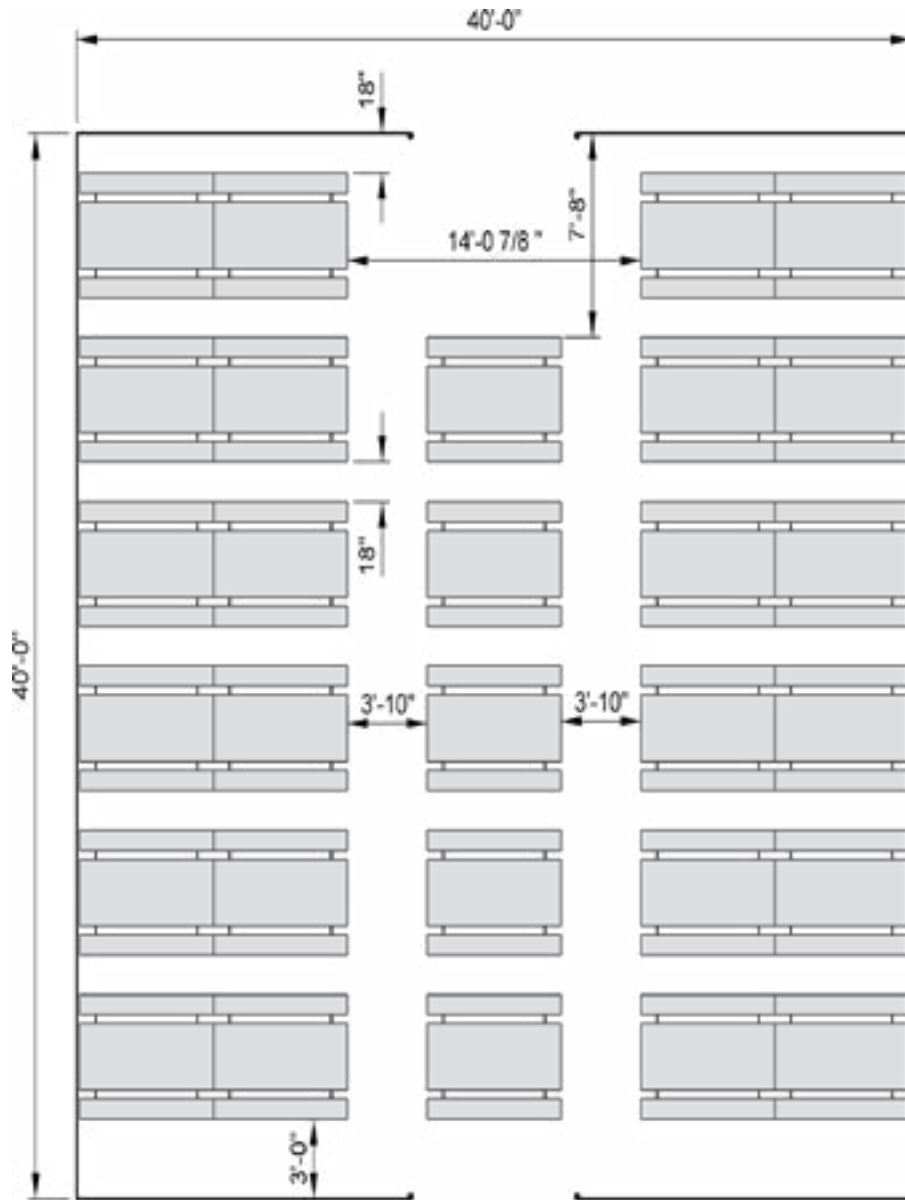

40' X 40' SHELTER

29 TABLES

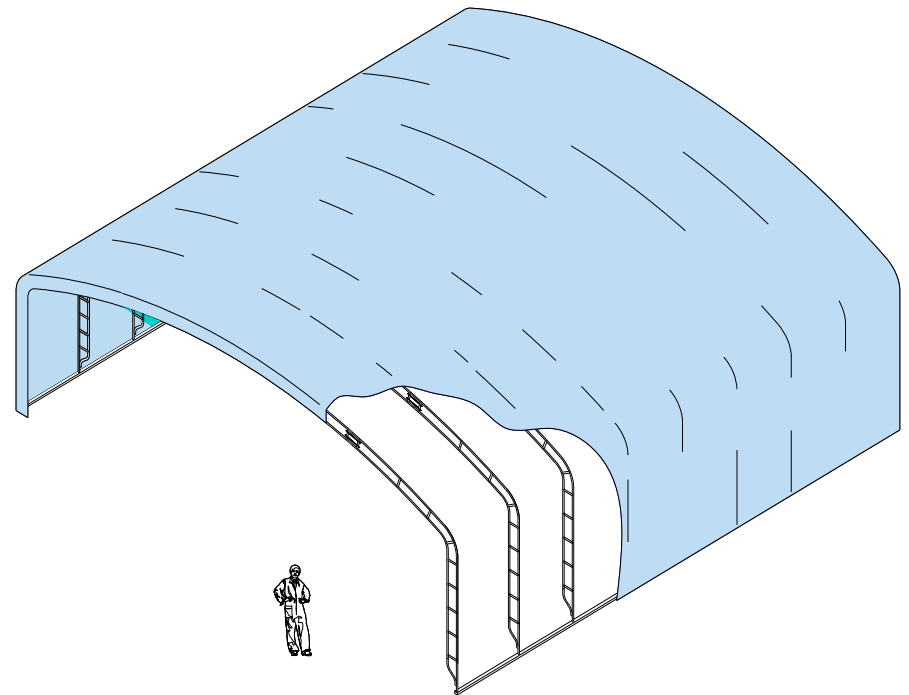
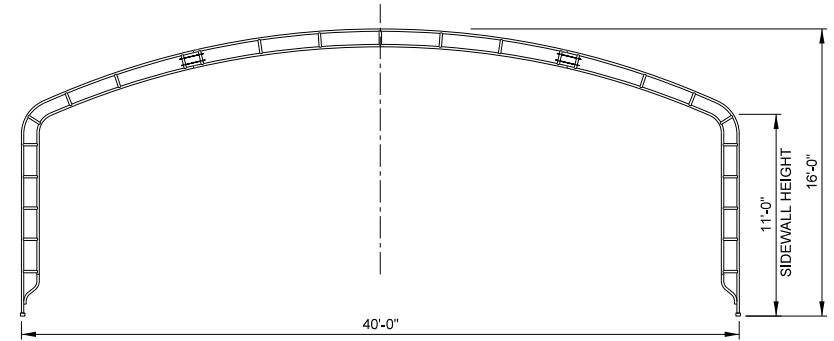
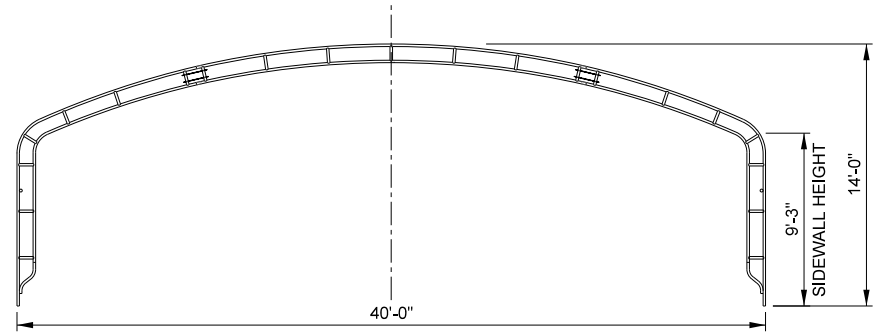

FABRIC SHELTER MATERIALS STORAGE TENT 40' WIDE MODELS

SIZE

40'W 16' at center 11' sidewall

FRAME

Truss Frame, High Strength Galvanized Steel Tubing

FABRIC

18 oz Poly Coated Vinyl Flame Resistant NFPA 701



TRUSS FABRIC SHELTER MATERIALS STORAGE 40' WIDE MODELS

SIZE

40'W 20'H at center; 12'-6" Sidewall

FRAME

Single Tube, High Strength Galvanized Steel Tubing

FABRIC

18 oz Poly Coated Vinyl Flame Resistant NFPA 701

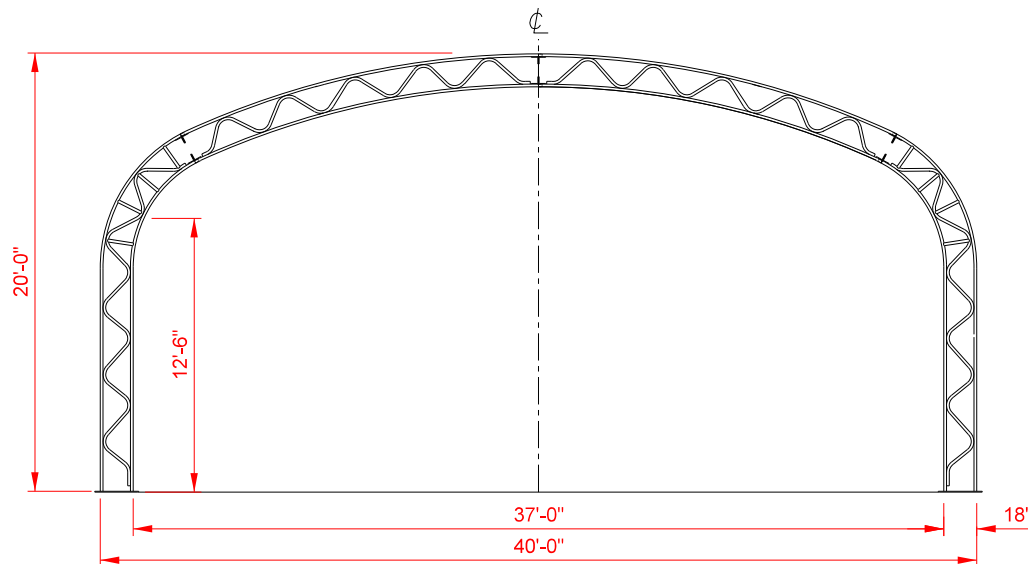

END PANELS

American Covers Inc. Fabric End Panels include a detailed assembly instruction manual along with packaging to include all hardware required for assembly. American Covers issues a color standard white for shelters, however, a variety of color options are available such as tan, grey, or green.



METAL ROLL UP DOORS



DUCT PORTS



INTERIOR CURTAINS



FABRIC ROLL UP DOORS



SOLID END PANEL



CLEAR STRIP DOORS

ACCESSORIES

Customize your lunch tent with accessories to make your onsite dining facility safe and comfortable.

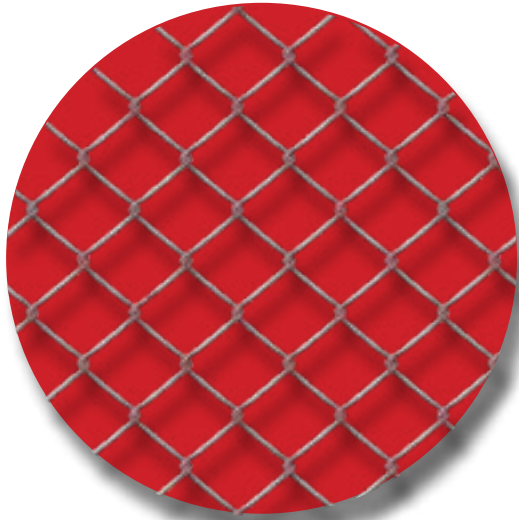

FENCING

American Covers Inc. is prepared to serve many temporary site needs, including safely securing a location and controlling crowds—privacy fencing is yet another accessory American Covers can include to your rental package.



LIGHTING

From easy to install light strings to full LED bay lights, American Covers offers lighting options to provide quality, bright, professional-grade illumination that is clear and long-lasting.

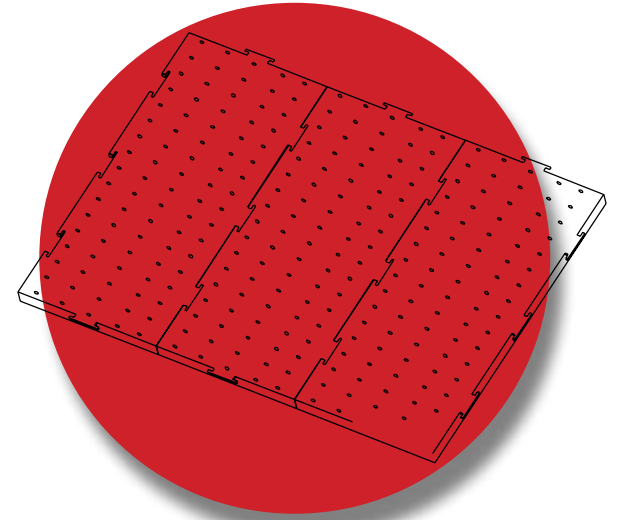

FLOORING

Modular temporary flooring that provides surface protection for lunch tents and event tents requiring floor stability and enhanced appearance. The PVC interlocking floor panels include drainage holes to keep the floor dry. Installation is easy and fast.



281 General Patton Avenue

Mandeville, LA 70471

877. 846. 4326

985. 778. 0700

Fax 985. 778. 0707

sales@americancoversinc.com

www.americancoversinc.com

