

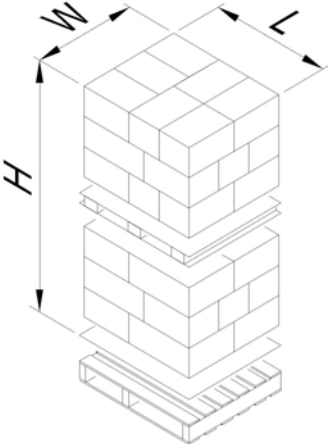

HOT EMULSION SBR PACKAGING

Packaging - HOT SBR Polymers – Bale/Crumb						
Product	Bale/Box Wt.	Number of Bales	New Skid Wt.	Package	No. of Boxes for Maximum Stacking Height	Package Code
1006	70 lbs.	36	2520 lbs.	Corrugated box with wooden pallet	2	P51
1006C	50 lbs.	42	2100 lbs.	Corrugated boxes on wooden pallet	2	P21
1009	70 lbs.	36	2520 lbs.	Corrugated box with wooden pallet	2	P51
1009C	50 lbs.	42	2100 lbs.	Corrugated boxes on wooden pallet	2	P21
1009AF	70 lbs.	36	2520 lbs.	Corrugated box with wooden pallet	2	P51
1009AFC	50 lbs.	42	2100 lbs.	Corrugated boxes on wooden pallet	2	P21
1011AC	70 lbs.	36	2520 lbs.	Corrugated box with wooden pallet	2	P58
1011AE	70 lbs.	36	2520 lbs.	Aluminum OTD Returnable Container	4	P45
1011AE	70 lbs.	36	2520 lbs.	Corrugated box with wooden pallet	2	P51
1012	70 lbs.	36	2520 lbs.	Corrugated box with wooden pallet	2	P58
1012C	40 lbs.	42	1680 lbs.	Corrugated boxes on wooden pallet	2	P25
1013	70 lbs.	36	2520 lbs.	Corrugated box with wooden pallet	2	P58
4503C	70 lbs.	36	2100 lbs.	Corrugated box with wooden pallet	2	P21
4503CX	1000 lbs.	1	1000 lbs.	Corrugated Octagon Bulk box with wooden pallet	3	P28

PACKAGE (P21 and P25)



PACKAGE (P28)

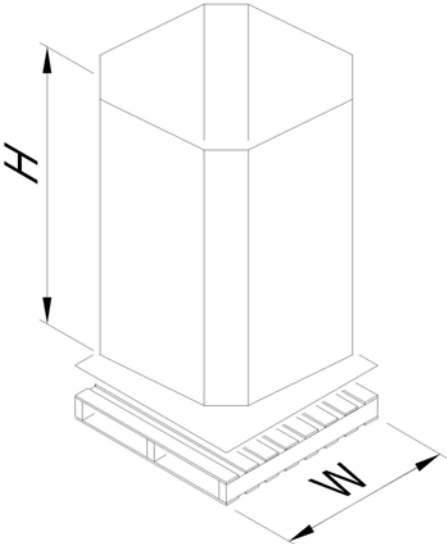

PACKAGE (P44, P45, P46)

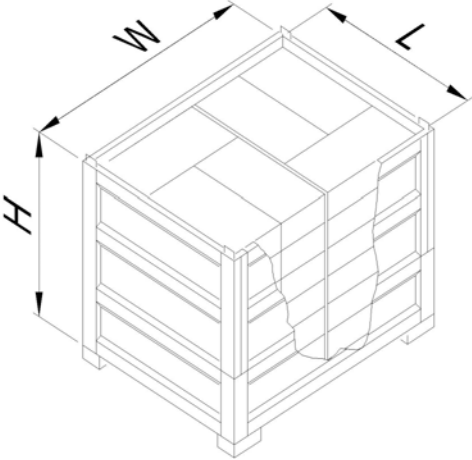

PACKAGE (P43)

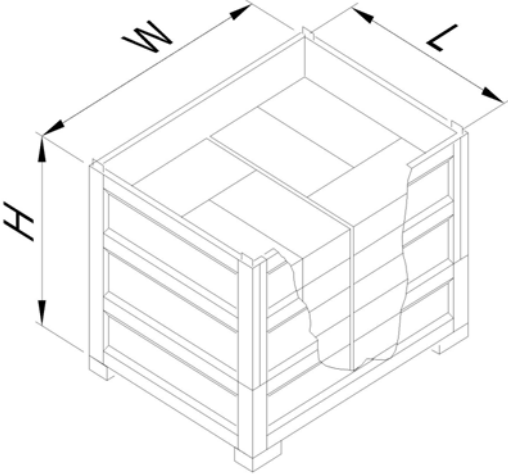

PACKAGE (P51, P58, P70, P79)

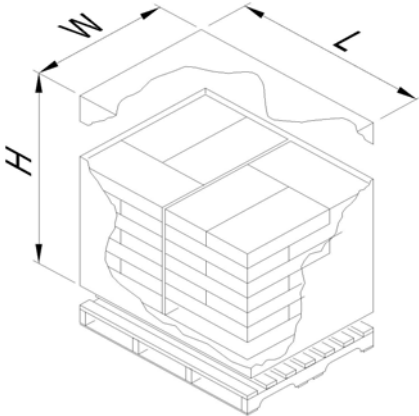

PACKAGE (P60, P63)

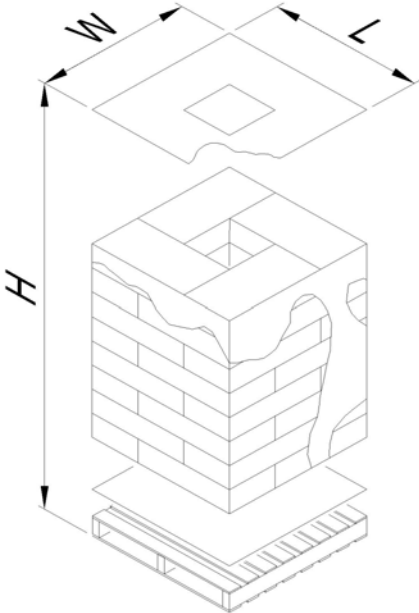

PACKAGE (GPMB4, GPMB5)

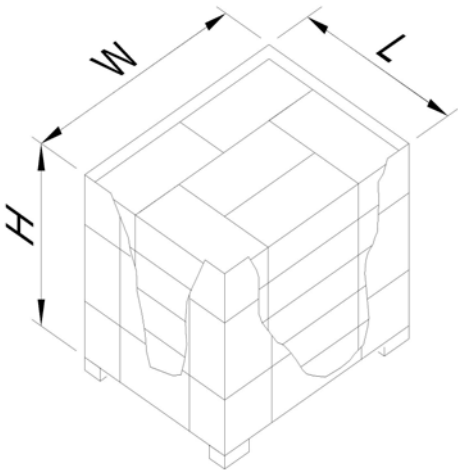

PACKAGE (P79)

